

REV	DESCRIPTION	DATE	APPROVED

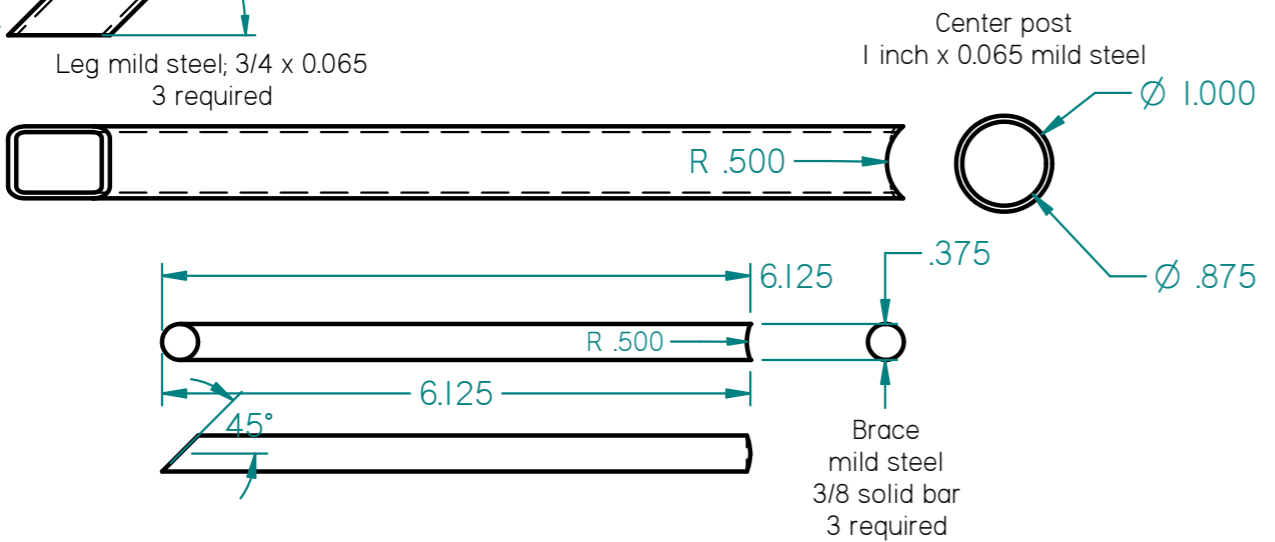
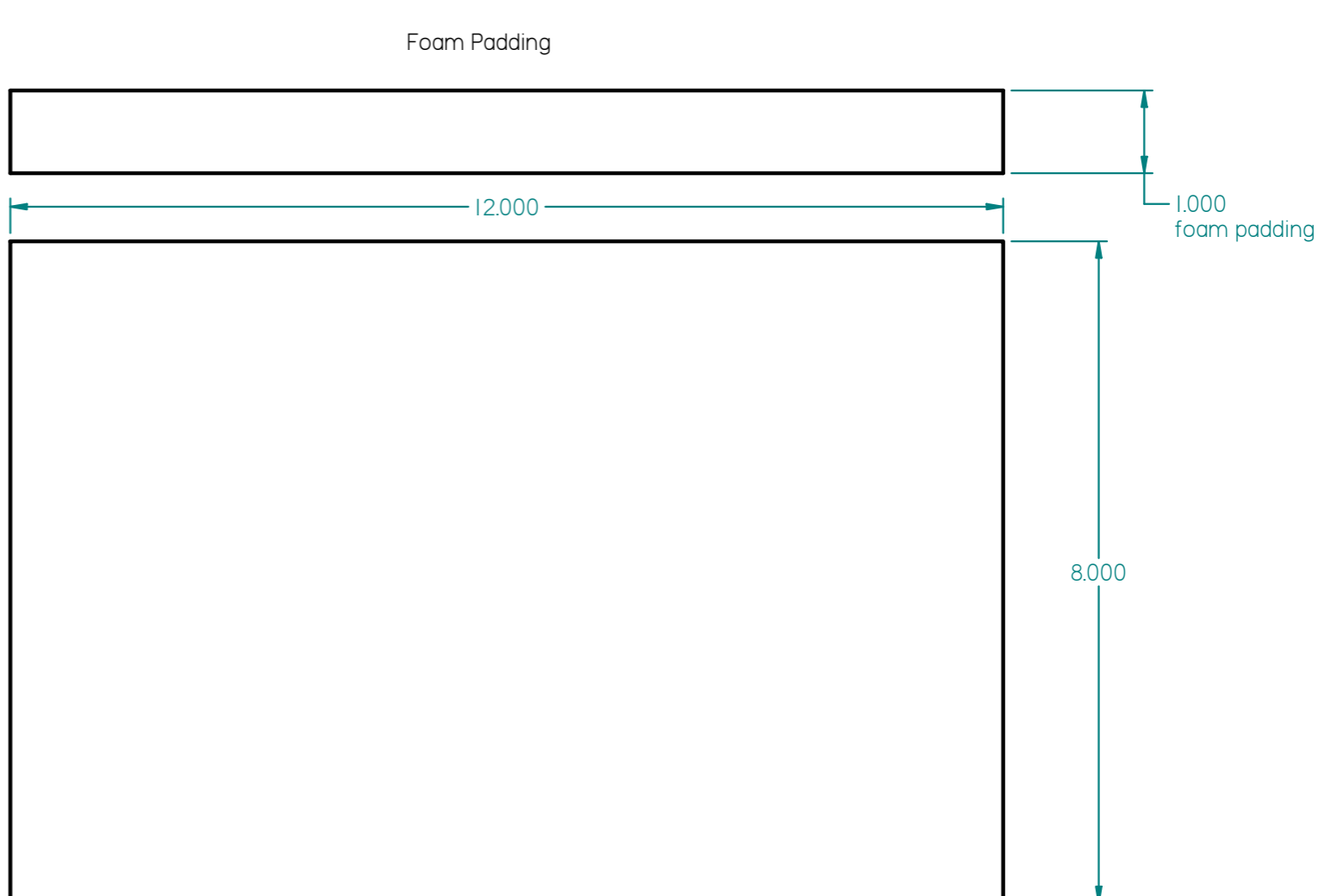
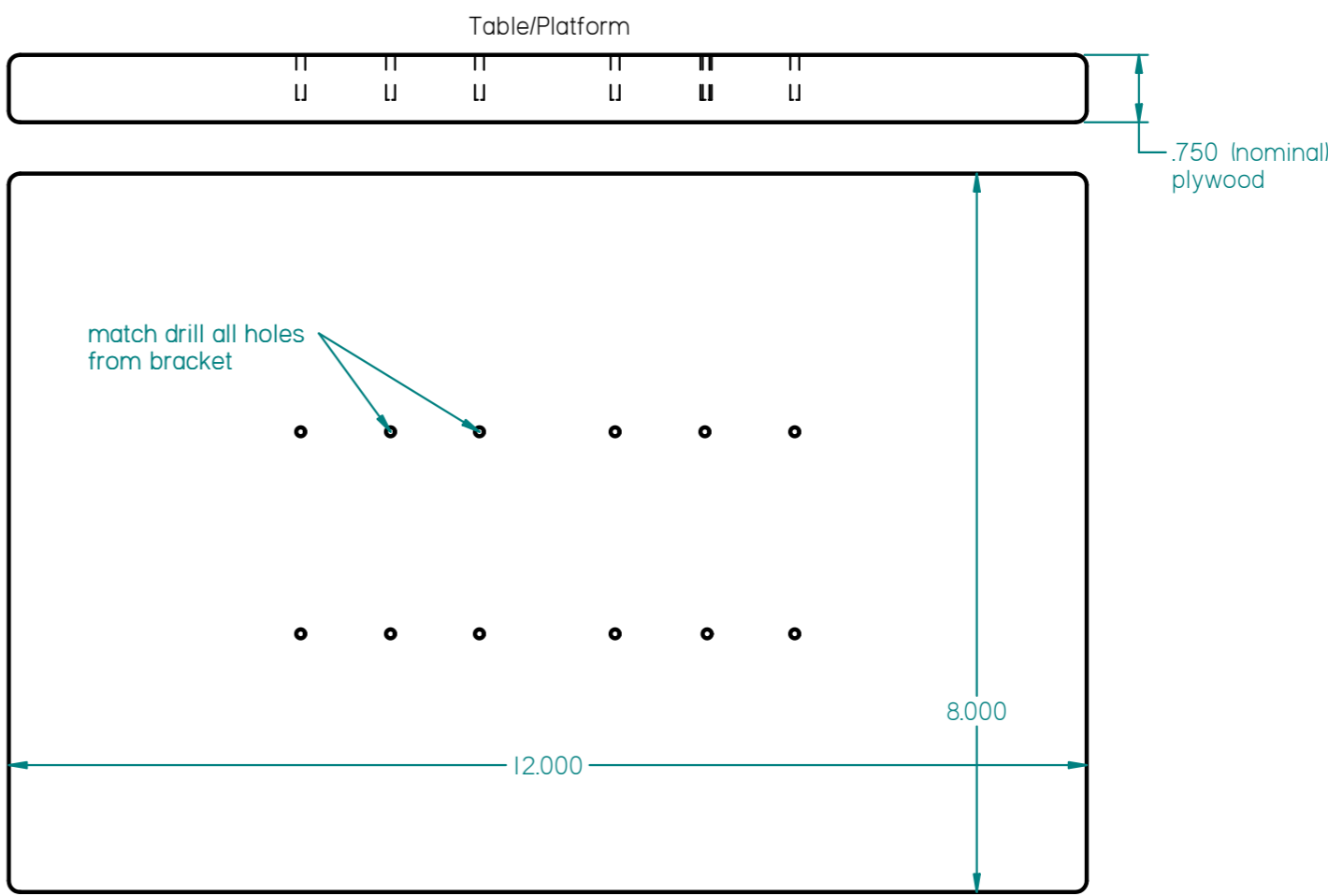
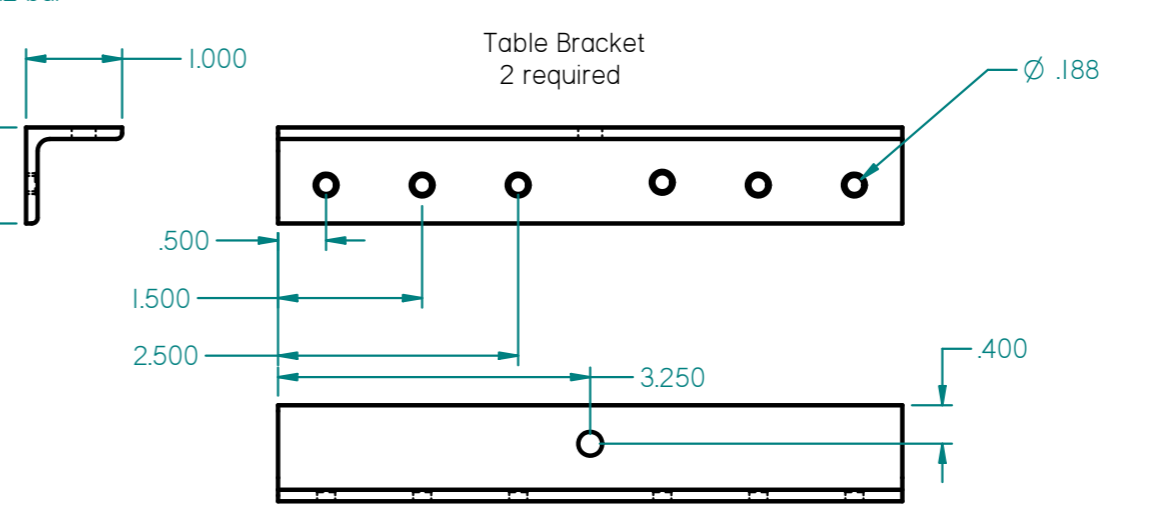
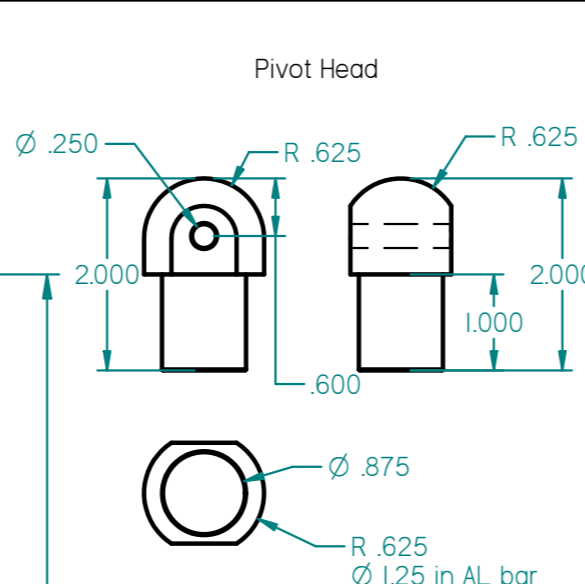
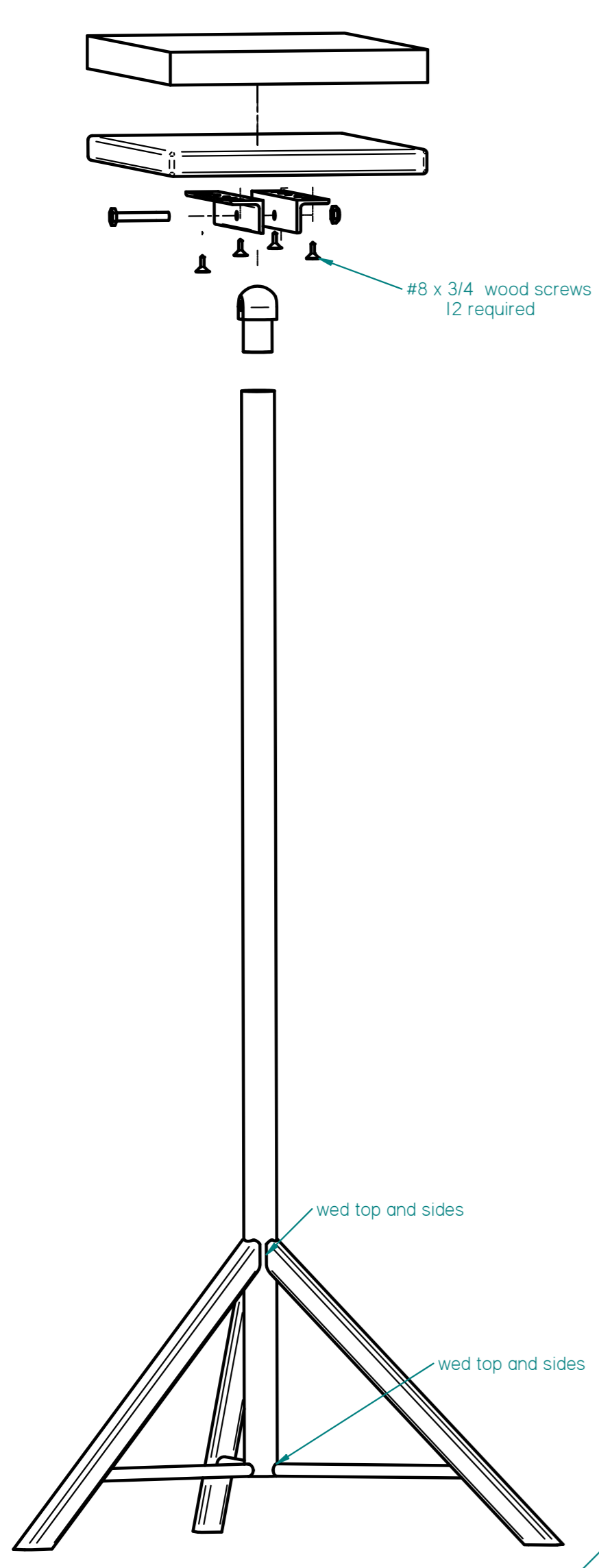
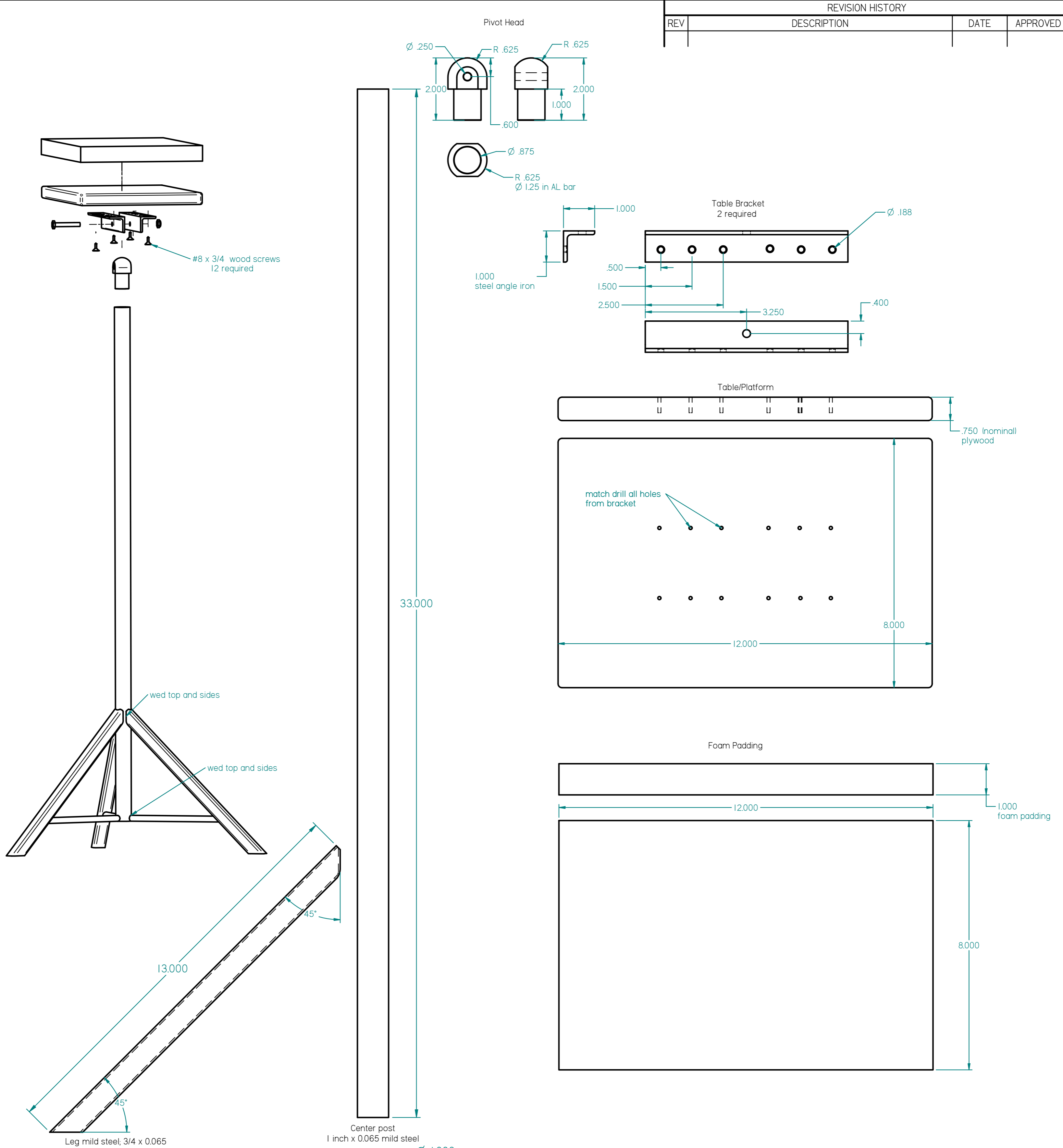

NAME	DATE		TITLE
DRAWN	08/09/23		Stand, tail for Jabiru
CHECKED			SIZE DWG NO
ENG APPR			D 8-902023BHDI
MGR APPR		UNLESS OTHERWISE SPECIFIED DIMENSIONS ARE IN INCHES ANGLES ±XX° 2 PL ±XXX 3 PL ±XXXX	REV
		SCALE:	WEIGHT:
			SHEET 1 OF 1