

SECTION G  
ROTATING MACHINERY

SECTION G1.2  
SOLID DISCS

## TABLE OF CONTENTS

	Page
G1.2 <u>SOLID DISKS.</u>	
1.2.1 CONSTANT (UNIFORM) THICKNESS .....	2
1.2.2 VARIABLE THICKNESS .....	3
1.2.3 EXAMPLE PROBLEMS FOR ROTATING SOLID CIRCULAR DISKS .....	4
I. Example Problem 1 .....	4
II. Example Problem 2 .....	7
REFERENCES .....	10

## DEFINITION OF SYMBOLS

### Symbol

$b$	Rim radius
$g$	Gravity constant
$h (r)$	Disk thickness at location $r$
$r$	Distance from axis of revolution
$\mu$	Poisson's ratio
$\rho$	Disk material density
$\sigma_r$	Stress in radial direction; positive denotes tension
$\sigma_\theta$	Stress in tangential (hoop) direction; positive denotes tension
$\omega$	Constant angular velocity, rad/sec

G1.2 SOLID DISKS.

In this section some of the methods of analyzing rotating circular disks are presented. The disks rotate about an axis which is perpendicular to the disk. Because the methods for a final analysis of turbomachinery-type hardware are quite involved, only methods for preliminary analysis which assume constant stress across the disk thickness are considered. Since the methods are preliminary, no modes of failure will be discussed at this time.

The geometry, coordinates, and stresses for a rotating circular disk are shown in Figure G1.2-1.

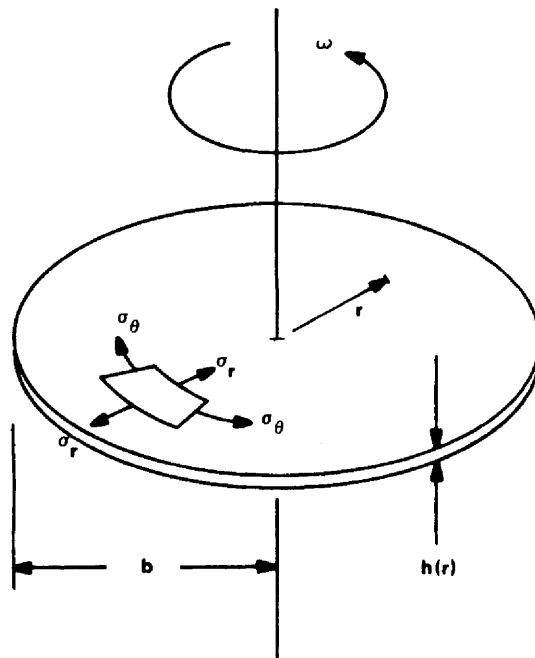

FIGURE G1.2-1. CONFIGURATION OF SOLID CIRCULAR DISK

1.2.1 CONSTANT (UNIFORM) THICKNESS.

For solid circular disks rotating at a constant angular velocity with uniform thicknesses and temperature fields, the radial and tangential stresses (Ref. 1) are

$$\sigma_r = \frac{(\rho v^2)(3 + \mu)(1 - x^2)}{8g} \quad (1)$$

and

$$\sigma_\theta = \frac{(\rho v^2)(3 + \mu)}{8g} \left[ 1 - \frac{(1 + 3\mu)x^2}{3 + \mu} \right] \quad (2)$$

where

$$x = \frac{r}{b} \quad (3)$$

and

$$v = b\omega \quad (4)$$

The maximum stress occurs at the center of the disk ( $r = 0$ ) and is given by

$$(\sigma_\theta)_{\max} = (\sigma_r)_{\max} = \frac{(\rho v^2)(3 + \mu)}{8g} \quad (5)$$

If the disk is centrally clamped (Fig. G1.2.1-1), the in-plane stresses (Ref. 2) become

$$\sigma_r = \left( \frac{\xi_2}{r^2} \right) (b^2 - r^2) \left( r^2 + \frac{\xi_1}{b^2 \xi_2} \right) \quad (6)$$

and

$$\sigma_{\theta} = \left( \frac{\xi_2}{r^2} \right) \left[ \left( b^2 - \frac{\xi_1}{b^2 \xi_2} \right) r^2 - \frac{\xi_1}{\xi_2} - \frac{(1 + 3\mu) r^4}{3 + \mu} \right] \quad (7)$$

where

$$\xi_1 = \frac{(1 - \mu) \rho \omega^2 a^2 b^2}{8} \left[ \frac{(3 + \mu) b^2 - (1 + \mu) a^2}{(1 + \mu) b^2 + (1 - \mu) a^2} \right] \quad (8)$$

and

$$\xi_2 = \frac{(3 + \mu) \rho \omega^2}{8} \quad (9)$$

for values of  $r$  greater than  $a$ .

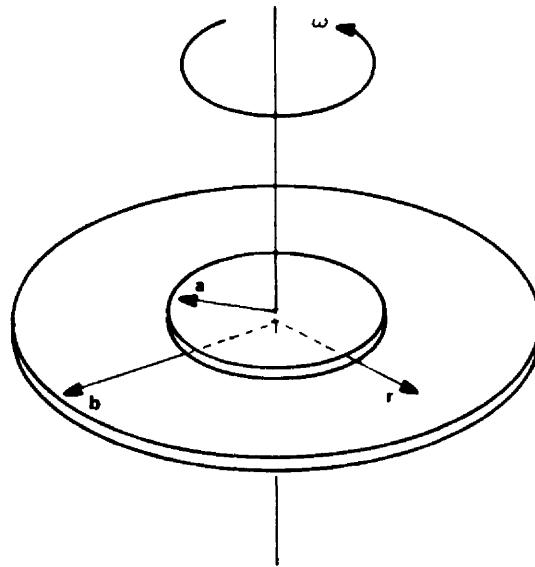

FIGURE G1.2.1-1. CONFIGURATION OF DISK WITH FULLY CLAMPED HUB

For a solid disk with a uniform thickness and a varying temperature field, the radial and tangential stresses are calculated using the procedure given in Paragraph 1.3.2 (Disks with a Hole at the Center — Variable Thickness) with the modifications described in Paragraph 1.2.2.

#### 1.2.2 VARIABLE THICKNESS.

For a solid circular disk rotating at a constant angular velocity with a varying thickness or a varying temperature field, the radial and tangential stresses (Ref. 3) are calculated using the procedure given in Paragraph 1.3.2 (Disks with a Hole at the Center — Variable Thickness) with the following modifications:

1. Station point 1 should be chosen at 5 percent of the rim radius (b).
2. The initial value in column 33 should be 1.0.
3. The stresses at the center of the disk ( $r = 0$ ) are assumed equal to the stresses at station point 1.

#### 1.2.3. EXAMPLE PROBLEMS FOR ROTATING SOLID CIRCULAR DISKS.

##### I. Example Problem 1.

Find the radial and tangential stresses for the solid circular disk shown in the following sketch.



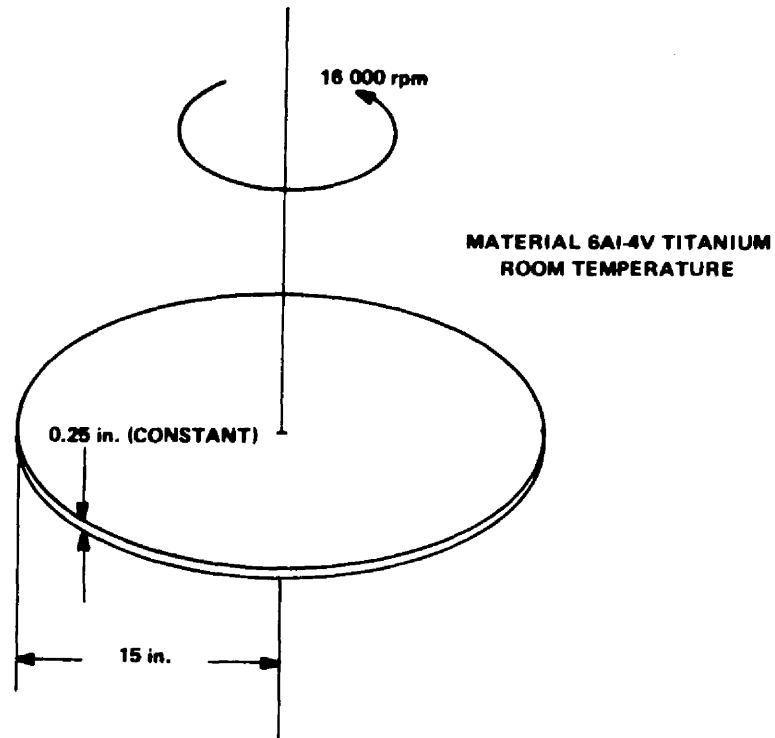

Solution:

$$E = 16.0 \times 10^6 \text{ lb/in.}^2 .$$

$$\rho = 0.16 \text{ lb/in.}^3 .$$

$$\mu = 0.313 .$$

$$g = 32.2 \text{ ft/sec}^2 = 386.4 \text{ in./sec}^2 .$$

$$\omega = 16\,000 \text{ rpm} = 266.7 \text{ r/sec} = 1675.52/\text{sec} .$$

From equation (4)

$$v = b\omega = 15 \times 1675.52 = 25\,132.8 \text{ in./sec}$$

and

$$v^2 = 6.3166 \times 10^8 \text{ in./sec}^2.$$

Equation (1) becomes

$$\begin{aligned} \sigma_r &= \frac{0.16 \times 6.3166 \times 10^8}{8 \times 3.864 \times 10^2} \times 3.313 \times \left(1 - \frac{r^2}{15^2}\right) \frac{\text{lb in.}^2 \text{ sec}^2}{\text{in.}^3 \text{ sec}^2 \text{ in.}} \\ &= 108\,310 \left(1 - \frac{r^2}{225}\right) \text{ lb/in.}^2 \end{aligned}$$

The following sketch depicts  $\sigma_r$ .

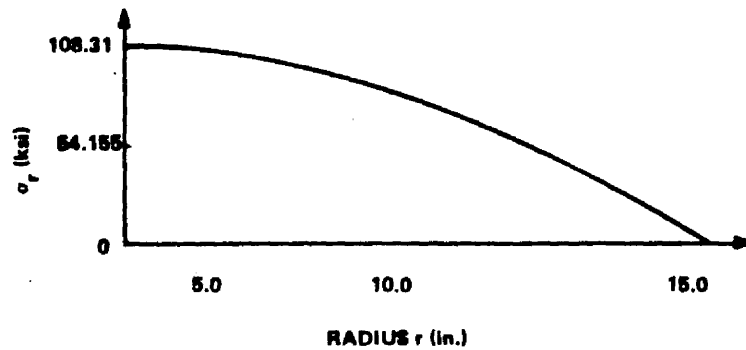

Equation (2) becomes

$$\sigma_\theta = 108\,310 \left(1 - \frac{r^2}{385}\right) \text{ lb/in.}^2$$

The following sketch depicts  $\sigma_\theta$ .

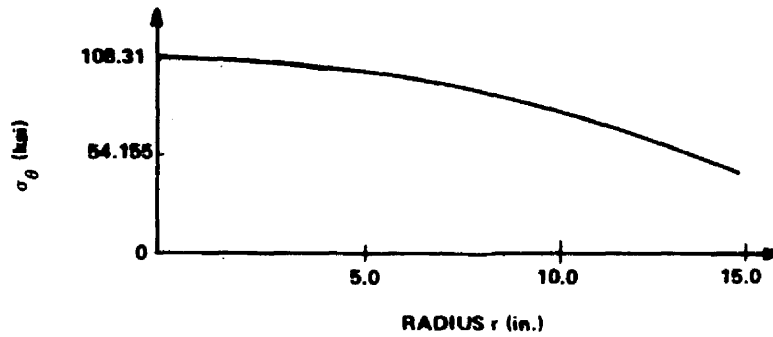

II. Example Problem 2.

Find the radial and tangential stresses for the solid circular disk shown in the following sketch.

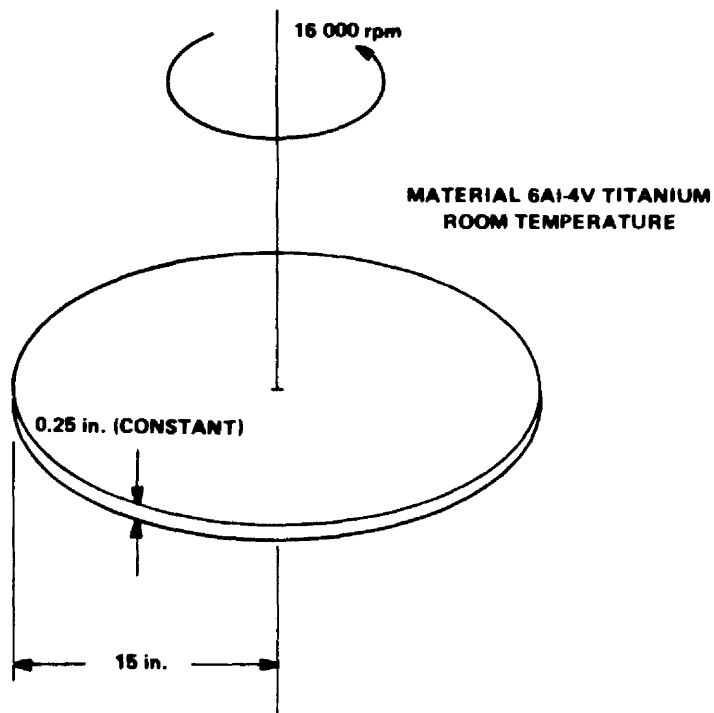

Solution:

$$E = 16.0 \times 10^6 \text{ lb/in.}^2 .$$

$$\rho = 0.16 \text{ lb/in.}^3 .$$

$$\mu = 0.313 .$$

$$g = 386.4 \text{ in./sec}^2 .$$

$$\omega = 16\,000 \text{ rpm}$$

$$= 1675.52/\text{sec} .$$

The idealization for the finite-difference-type analysis is given in the following sketch.

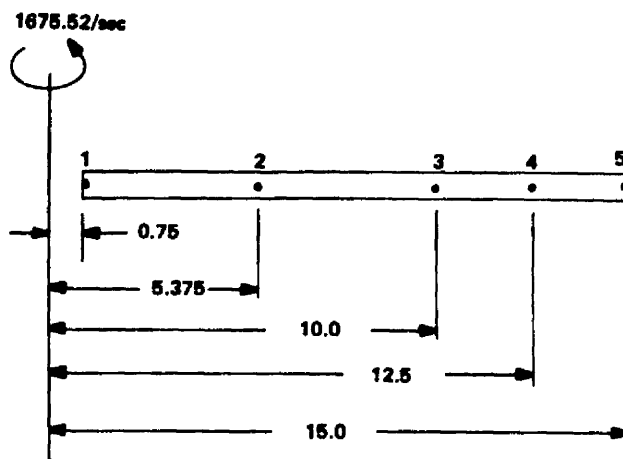

NOTE: DIMENSIONS ARE IN INCHES.

The computations for the finite-difference-type analysis are given in Table G1.2.3-1.

Table G1.2.3-1. Finite-Difference Analysis Computations of Example Problem 2

n	$r_n$	$h_n$	$\rho_n^{-2} \times 386.4$	$\mu_n$	$E_n$	$\alpha_n$	$\Delta T_n$	(1) $\times$ (2)	$\frac{[(1) - (1)_{n-1}]}{+2.0}$	(2) $\times$ (9)	(2) $_{n-1} \times$ (9)	(3) $\times$ (9) $\times$ (4)	(12) $+$ (12) $_{n-1}$
n	1	2	3	4	5	6	7	8	9	10	11	12	13
1	0.75	0.25	1151	0.313	$16.0 \times 10^{-6}$	$\alpha$	0	0.1875	-	-	-	161.3594	-
2	5.375	0.25	1151	0.313	16.0	$\alpha$	0	1.3438	2.3125	0.5781	0.5781	8313.5567	8475.45
3	10.0	0.25	1151	0.313	16.0	$\alpha$	0	2.5	2.3125	0.5781	0.5781	28775	37088.59
4	12.5	0.25	1151	0.313	16.0	$\alpha$	0	3.125	1.25	0.3125	0.3125	44960.9375	73735.94
5	15.0	0.25	1151	0.313	16.0	$\alpha$	0	3.75	1.25	0.3125	0.3125	64743.75	109704.69

n	(3) $\times$ (13)	1.0 $\times$ (5)	(4) $\times$ (15)	$[1.0 \times (4)] \times (15) \div (4)$	(17) $\times$ (9)	$(17)_{n-1} \times (9)$	(16) $+$ (18)	(15) $-$ (18)	$(16)_{n-1} - (19)$	$(15)_{n-1} - (19)$	(6) $\times$ (7)	(24) $-$ (24) $_{n-1}$	(20) $\times$ (10) $-$ (8) $\times$ (21)
n	14	15	16	17	18	19	20	21	22	23	24	25	26
1	-	$0.0625 \times 10^{-5}$	$0.0198 \times 10^{-5}$	$0.1094 \times 10^{-5}$	-	-	-	-	-	-	0	0	-
2	$0.0195 \times 10^8$	0.0625	0.0196	0.0153	$0.0354 \times 10^{-5}$	$0.2530 \times 10^{-5}$	$0.055 \times 10^{-5}$	$0.0979 \times 10^{-5}$	$-0.2334 \times 10^{-5}$	$-0.1905 \times 10^{-5}$	0	0	$-0.0991 \times 10^{-5}$
3	0.0553	0.0625	0.0196	0.0082	0.019	0.0354	0.0086	0.0815	-0.0158	0.0271	0	0	-0.1514
4	0.0922	0.0625	0.0196	0.0066	0.00825	0.0103	0.02785	0.07075	0.0093	0.0522	0	0	-0.2124
5	0.1371	0.0625	0.0196	0.0055	0.0069	0.00825	0.0263	0.0694	0.0114	0.0543	0	0	-0.2520

n	$\frac{[(22) \times (19)] \times (21)}{+ (26)}$	$\frac{[(23) \times (4)] \times (21)}{+ (26)}$	$\frac{[(8) \times (22)] \times (21)}{+ (26)}$	$\frac{[(20) \times (11)] \times (23)}{+ (26)}$	$\frac{[(25) \times (19)] \times (21)}{+ (26)}$	$\frac{[(20) \times (14)] \times (5) \times (25)]}{+ (26)}$	$\frac{[(27) \times (33)]_{n-1}}{-(25) \times (34)_{n-1}}$	$\frac{[(29) \times (31)]_{n-1}}{-(30) \times (34)_{n-1}}$	$\frac{[(27) \times (35)]_{n-1}}{-(25) \times (36)_{n-1}}$	$\frac{[(29) \times (35)]_{n-1}}{+(30) \times (36)_{n-1}}$	$\frac{[\sigma_{r,b} - (35)]_b}{+ (33)_b}$	$\frac{\sigma_{r,n}}{(33) \times (37) - (35)}$	$\frac{\sigma_{\theta,n}}{(34) \times (37) + (36)}$
n	27	28	29	30	31	32	33	34	35	36	37	38	39
1	-	-	-	-	-	-	1.0	1.0	0.0	0.0	$0.1137 \times 10^7$	$0.1136 \times 10^5$	$0.1136 \times 10^6$
2	1.5467	-0.5402	3.2694	-2.2624	$-0.0192 \times 10^8$	$-0.0111 \times 10^5$	1.0065	1.007	$-0.0192 \times 10^5$	$-0.0111 \times 10^6$	0.1137	0.0952	0.1033
3	0.6540	0.3461	0.5036	0.4967	-0.0386	-0.0182	1.0068	1.007	-0.055	-0.0334	0.1137	0.0595	0.081
4	0.8190	0.1909	0.1902	0.8088	-0.0306	-0.0122	1.0068	1.006	-0.0817	-0.0497	0.1137	0.0329	0.0646
5	0.8464	0.1536	0.1589	0.8409	-0.0377	-0.0143	1.0068	1.0069	-0.1145	-0.0691	0.1137	0.0	0.0452

## REFERENCES

1. Timoshenko, S. : Strength of Materials, Part II. D. Van Nostrand and Company, Inc., New York, 1956, p. 218.
2. Eversman, W.; and Dodson, Jr., R. O. : Free Vibration of a Centrally Clamped Spinning Circular Disk. AIAA Journal, vol. 7, no. 10, Oct. 1969, pp. 2010 - 2012.
3. Manson, S. S. : Determination of Elastic Stresses in Gas-Turbine Disks. NACA Report 871, Cleveland, Ohio, Feb. 27, 1947.

# TABLE OF CONTENTS

	Page
G1.3 <u>DISKS WITH A HOLE AT THE CENTER</u> . . . . .	11
1.3.1 CONSTANT (UNIFORM) THICKNESS. . . . .	11
1.3.2 VARIABLE THICKNESS. . . . .	13
1.3.3 EXAMPLE PROBLEMS FOR ROTATING CIRCULAR DISKS WITH CENTER HOLES, . . . . .	16
I. Example Problem 1. . . . .	16
II. Example Problem 2. . . . .	20
REFERENCES. . . . .	24

## DEFINITION OF SYMBOLS

Symbol	Definition
$a$	Inner surface radius
$b$	Rim radius
$E$	Modulus of elasticity
$g$	Gravity constant
$h(r)$	Disk thickness at location $r$ .
$n$	Node (station) index
$r$	Distance from axis of revolution
$T$	Temperature ( $^{\circ}F$ )
$\alpha$	Coefficient of thermal expansion
$\mu$	Poisson's ratio
$\rho$	Disk material density
$\sigma_r$	Stress in radial direction; positive denotes tension
$\sigma_{\theta}$	Stress in tangential (hoop) direction; positive denotes tension
$\omega$	Constant angular velocity (rad/sec)



G1.3 DISKS WITH A HOLE AT THE CENTER.

In this section some of the methods of analyzing rotating circular disks with circular cutouts at the center are presented. The disks rotate about an axis which is perpendicular to the disk. Because the methods for a final analysis of turbomachinery-type hardware are quite involved, only methods for preliminary analysis which assume constant stress, or linearly varying stress, across the disk thickness are considered. Since the methods are preliminary, no modes of failure will be discussed at this time.

The geometry, coordinates, and stresses for a rotating circular disk are shown in Figure G1.3-1.

1.3.1 CONSTANT (UNIFORM) THICKNESS.

For circular disks with a center hole that rotate at a constant angular velocity with uniform thickness and temperature fields, the radial and tangential stresses (Ref. 1) are

$$\sigma_r = \frac{(\rho v^2)(3 + \mu)}{8g} \left( 1 + \gamma^2 - x^2 - \frac{\gamma^2}{x^2} \right) \quad (1)$$

and

$$\sigma_\theta = \frac{(\rho v^2)(3 + \mu)}{8g} \left( 1 + \gamma^2 - \frac{(1 + 3\mu)x^2}{3 + \mu} + \frac{\gamma^2}{x^2} \right) \quad (2)$$

where

$$\gamma = \frac{a}{b} \quad , \quad (3)$$

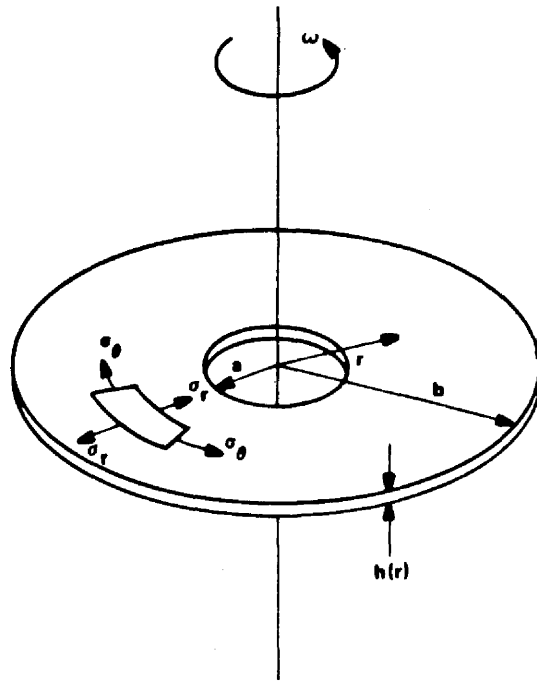

FIGURE G1.3-1. CONFIGURATION OF A CIRCULAR DISK WITH A CENTER HOLE

$$x = \frac{r}{b} \quad , \quad (4)$$

and

$$v = b \omega \quad . \quad (5)$$

The maximum stresses occur at  $r = \sqrt{ab}$  and are

$$(\sigma_r)_{\max} = \frac{(\rho v^2) (3 + \mu) (1 - \gamma)^2}{8g} \quad (6)$$

and

$$(\sigma_\theta)_{\max} = \frac{(\rho v^2) (3 + \mu)}{4g} \left[ 1 + \frac{(1 - \mu) \gamma^2}{3 + \mu} \right] . \quad (7)$$

The stresses may be determined by the computer program documented in a NASA technical note.<sup>1</sup>

For a disk with a uniform thickness and a varying temperature field, the radial and tangential stresses are calculated using the procedure given in Paragraph 1.3.2.

#### 1.3.2 VARIABLE THICKNESS.

The stresses in a circular disk with a center hole and a variable thickness or a variable temperature field may be determined using a finite-difference method (Ref. 2). This method considers the point-to-point variation in thickness, temperature, and material properties. The computations are easily executed in a tabular format.

An idealization of the disk is made (Fig. G1.3.2-1) by selecting stations along the radius. Station 1 lies on the inner surface, and station N lies on the outer (rim) surface.

Intermediate stations should be located at distances of 1, 2, 3, and 5 percent of the rim diameter from the inside boundary and at locations of thickness, temperature, or material property variations. The radius at each

---

1. Byron Foster and Jerrell Thomas: Automated Shell Theory for Rotating Structures (ASTROS). NASA TN-D-, Marshall Space Flight Center, to be published.

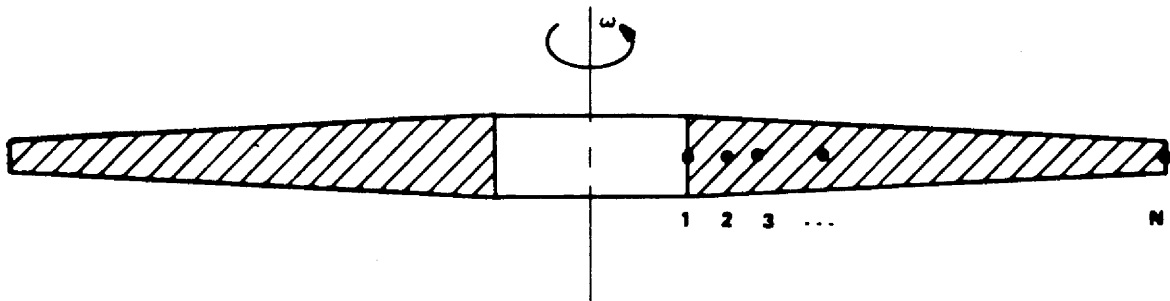

FIGURE G1.3.2-1. IDEALIZATION OF DISK FOR  
FINITE-DIFFERENCE ANALYSIS

station is entered in column 1 (Table G1.3.2-1). In column 2 the idealized thickness is entered. If a sharp discontinuity in thickness occurs, such as an abrupt flange, the thickness should be faired in the disk contour, and the faired disk used in determining the thickness. The mass density (corrected if in a faired section) multiplied by the square of the rotational speed is entered in column 3. Poisson's ratio and the modulus of elasticity are entered in columns 4 and 5, respectively. The coefficient of thermal expansion, which must be an average value applicable to the range between the temperature actually existing and the temperatures at which there is no thermal stress, is entered in column 6. The difference between the actual temperature and the temperature at which there is no thermal stress is entered in column 7.

The manipulations required in columns 8 through 34 are shown in the

Table G1.3.2-1. Finite-Difference Analysis Tabular Format

	1	2	3	4	5	6	7	8	9	10	11	12	13
n	$r_n$	$h_n$	$\rho_n = 2.346 \cdot 4$	$u_n$	$E_n$	$\alpha_n$	$\Delta T_n$	(1) × (2)	$(11) - (11)_{n-1} + 2.0$	(2) - (3)	$(2)_{n-1} - (9)$	(3) × (8) × (1)	(12) × (12) <sub>n-1</sub>
	14	15	16	17	18	19	20	21	22	23	24	25	26
n	(9) - (13)	1.0 + (5)	(4) - (15)	$[(5) + (4)] - (15) + (1)$	(17) × (9)	(17) <sub>n-1</sub> × (9)	(16) × (18)	(15) - (18)	$(15)_{n-1} - (19)$	$(15)_{n-1} - (19)$	(6) - (7)	(24) - (24) <sub>n-1</sub>	$(20) \times (10) - (5) \times (21)$
	27	28	29	30	31	32	33	34	35	36	37	38	39
n	$[(22) \times (18) - (5)_{n-1} \times (21)] + (26)$	$[(23) \times (19) - (11) \times (21)] + (26)$	$[(18) \times (22) - (20) \times (8)_{n-1}] + (26)$	$[(20) \times (11) - (8) \times (29)] + (26)$	$[(25) \times (19) - (14) \times (21)] + (26)$	$[(29) \times (13) - (5) \times (29)] + (26)$	$[(27) \times (32)_{n-1} - (28) \times (34)_{n-1}] + (26)$	$[(29) \times (32)_{n-1} - (30) \times (34)_{n-1}] + (26)$	$[(31) \times (33)_{n-1} - (18) \times (36)_{n-1}] + (11)$	$[(24) \times (37)_{n-1} + (30) \times (16)_{n-1} - (32)]$	$[\sigma_{r,b} - (35)_{n-1}] + (35)_n$	$\sigma_{r,n} = (33) \times (37) + (35)$	$\sigma_{z,n} = (34) \times (37) + (36)$

respective columns. Columns 33 and 34 are calculated simultaneously, with column 33 having an initial value of 0.000 and column 34 having an initial value of 1.000. Columns 35 and 36 are also calculated simultaneously, but each has an initial value of 0.000.

In column 37, the term  $\sigma_{r,b}$  denotes the blade loading at the rim and is obtained by dividing the total centrifugal force at the roots of the blades by the total rim peripheral area.

The radial stress,  $\sigma_r$ , at each station is calculated in column 38. The tangential stress,  $\sigma_\theta$ , at each station is calculated in column 39.

In using the finite-difference method, the accuracy of the results increases as the number of station points increases. The stresses may also be determined by the computer program already cited.<sup>2</sup>

### 1.3.3 EXAMPLE PROBLEMS FOR ROTATING CIRCULAR DISKS WITH CENTER HOLES

#### I. Example Problem 1.

Find the radial and tangential stresses for the following circular disk:

---

2. Ibid.

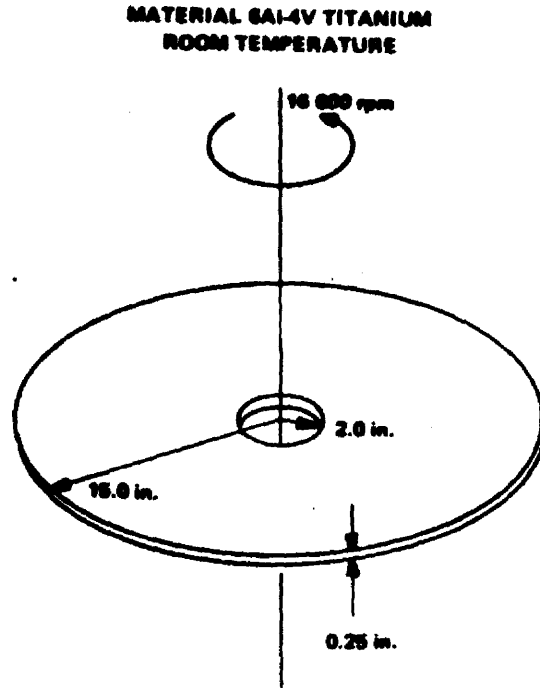

Solution:

$$E = 16.0 \times 10^6 \text{ psi,}$$

$$\rho = 0.16 \text{ lb/in.}^3,$$

$$\mu = 0.313,$$

$$g = 386.4 \text{ in./sec}^2,$$

$$\omega = 16\,000 \text{ rpm} = 1675.52/\text{sec},$$

$$\gamma = \frac{2}{15} = 0.1333,$$

$$v = 15 \times 1675.52 \text{ in./sec} = 25\,132.8 \text{ in./sec.}$$

and

$$v^2 = 6.3167 \times 10^8 \text{ in}^2/\text{sec}^2 .$$

Equation (1) becomes

$$\sigma_r = \frac{(0.16 \times 6.3167 \times 10^8)(3.0 + 0.313) \left(1 + 0.1333^2 - \frac{r^2}{225} - \frac{4.005}{r^2}\right)}{3091.2} \text{ psi}$$

$$= 1.0832 \times 10^5 \left(1.0178 - 0.00444 r^2 - \frac{4.005}{r^2}\right) \text{ psi.}$$

The following sketch depicts  $\sigma_r$ .

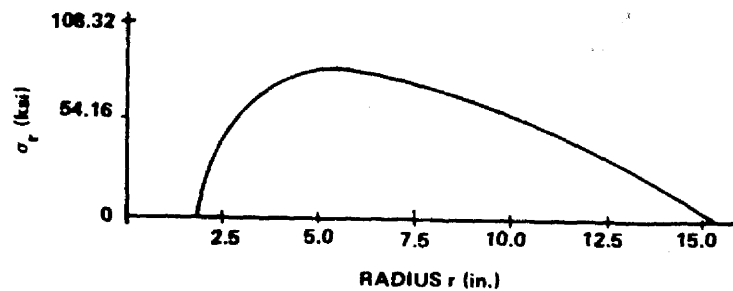

Equation (2) becomes

$$\sigma_\theta = 1.0832 \times 10^5 \left(1 + 0.1333^2 - \frac{1 + 0.939}{(3 + 0.313) 225} r^2 + \frac{4.005}{r^2}\right) \text{ psi.}$$

$$= 1.0832 \times 10^5 \left(1.0178 - 0.00444 r^2 - \frac{4.005}{r^2}\right) \text{ psi.}$$

The following sketch depicts  $\sigma_\theta$ .



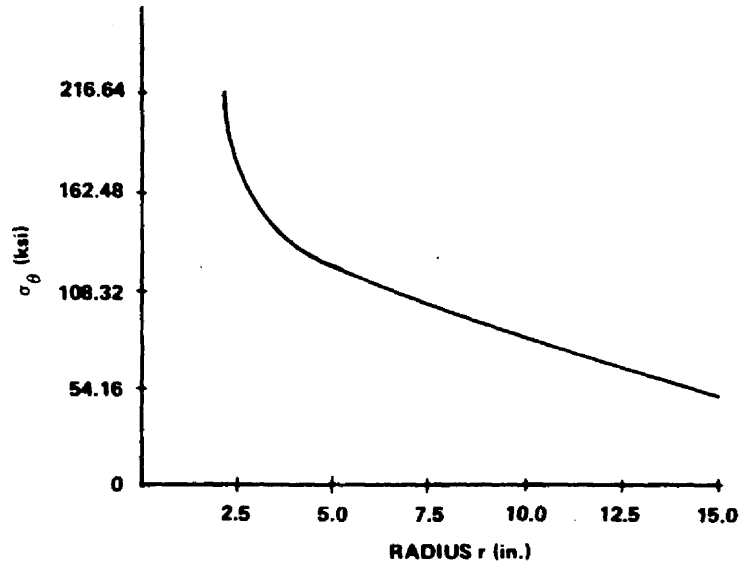

The maximum stress occurs at

$$r = 5.4772 \text{ in.}$$

The stresses at that position are

$$\sigma_r = 1.0832 \times 0.7511 \times 10^5 \text{ psi}$$

$$= 0.8136 \times 10^5 \text{ psi}$$

and

$$\sigma_\theta = 1.0832 \times 1.0733 \times 10^5 \text{ psi}$$

$$= 1.1626 \times 10^5 \text{ psi.}$$

II. Example Problem 2.

Find the radial and tangential stresses for the following circular disk.

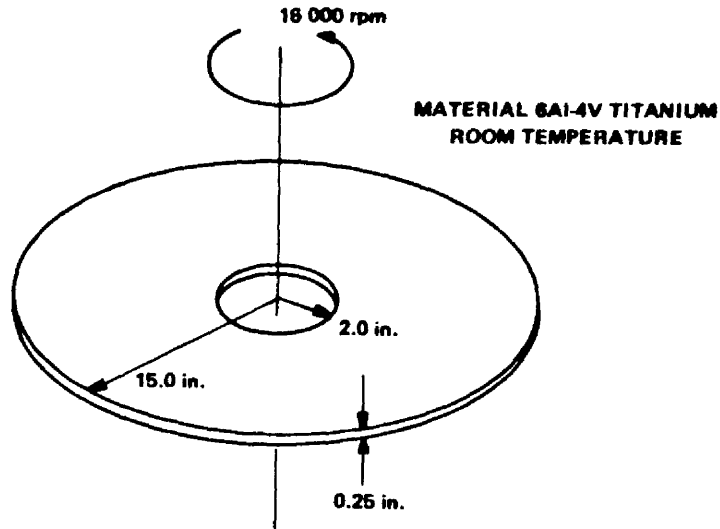

Solution:

$$E = 16.0 \times 10^6 \text{ psi.}$$

$$\rho = 0.16 \text{ lb/in.}^3$$

$$\mu = 0.313.$$

$$g = 386.4 \text{ in./sec}^2.$$

$$\omega = 16\,000 \text{ rpm} = 1675.52/\text{sec.}$$

The idealization for the finite-difference-type analysis is given in the following sketch.

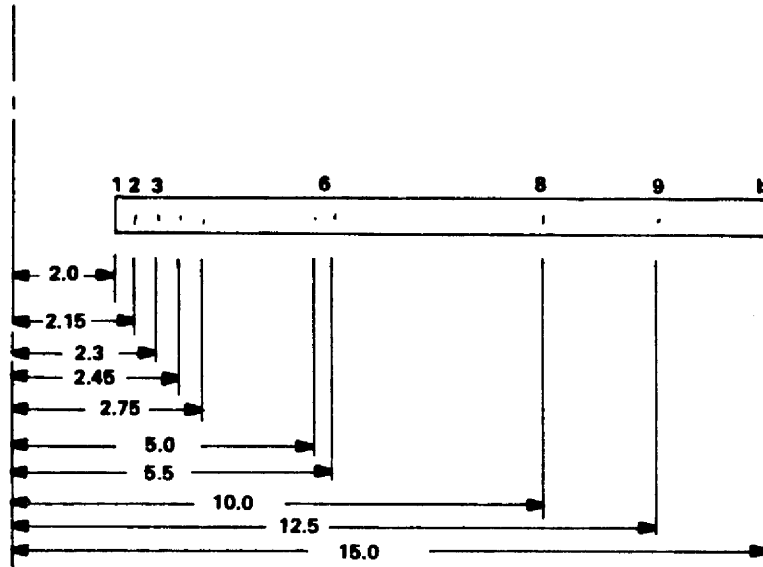

NOTE: DIMENSIONS ARE IN INCHES

The computations for the finite-difference-type analysis are given in Table G1,3.3-1.

Table G1.3.3-1. Finite-Difference Analysis Computations of Example Problem 2

n	$r_n$	$h_n$	$\rho_n \omega^2 / 386.4$	$\mu_n$	$E_n$	$\alpha_n$	$\Delta T_n$	(1) × (2)	$[(1) - (1)_{n-1}]$ + 2.0	(2) × (9)	$(2)_{n-1} \times (9)$	(3) × (8) × (1)	$(12) + (12)_{n-1}$
n	1	2	3	4	5	6	7	8	9	10	11	12	13
1	2.0	0.25	1162.5	0.313	$16.0 \times 10^6$	$\alpha$	0.00	0.5	-	-	-	1 162.5	-
2	2.15	0.25	1162.5	0.313	16.0	$\alpha$	0.00	0.5375	0.075	0.0188	0.0188	1 343.4142	2 505.9
3	2.3	0.25	1162.5	0.313	16.0	$\alpha$	0.00	0.575	0.075	0.0188	0.0188	1 537.4062	2 880.8
4	2.45	0.25	1162.5	0.313	16.0	$\alpha$	0.00	0.6125	0.075	0.0188	0.0188	1 744.4764	3 281.9
5	2.75	0.25	1162.5	0.313	16.0	$\alpha$	0.00	0.6875	0.15	0.0375	0.0375	2 197.8517	3 942.3
6	5.0	0.25	1162.5	0.313	16.0	$\alpha$	0.00	1.25	1.125	0.2812	0.2812	7 265.625	9 463.5
7	5.5	0.25	1162.5	0.313	16.0	$\alpha$	0.00	1.375	0.25	0.0625	0.0625	8 791.4062	16 057.0
8	10.0	0.25	1162.5	0.313	16.0	$\alpha$	0.00	2.5	2.25	0.5625	0.5625	29 062.5	37 853.9
9	12.5	0.25	1162.5	0.313	16.0	$\alpha$	0.00	3.255	1.25	0.3125	0.3125	47 299.219	76 361.7
b	15.0	0.25	1162.5	0.313	16.0	$\alpha$	0.00	3.75	1.25	0.3125	0.3125	65 390.625	112 689.8

Table G1.3.3-1 (CONCLUDED)

n	(9) × (13)	1.0 + (5)	(4) × (15)	[1.0 + (4)] × (15) + (1)	(17) × (9)	(17) <sub>n-1</sub> × (9)	(16) + (18)	(15) + (18)	(16) <sub>n-1</sub> - (19)	(15) <sub>n-1</sub> - (19)	(6) × (7)	(24) - (24) <sub>n-1</sub>	(20) × (10) - (8) × (21)
	14	15	16	17	18	19	20	21	22	23	24	25	26
1	-	0.0625 × 10 <sup>-6</sup>	0.0196 × 10 <sup>-6</sup>	0.0411 × 10 <sup>-6</sup>	-	-	-	-	-	-	0.0	0.0	-
2	197.94	0.0625	0.0196	0.0382	0.0029 × 10 <sup>-6</sup>	0.0031 × 10 <sup>-6</sup>	0.0225 × 10 <sup>-6</sup>	0.0654 × 10 <sup>-6</sup>	0.0165 × 10 <sup>-6</sup>	0.0594 × 10 <sup>-6</sup>	0.0	0.0	-0.0347 × 10 <sup>-6</sup>
3	246.06	0.0625	0.0196	0.0357	0.0027	0.0029	0.0223	0.0652	0.0167	0.0596	0.0	0.0	-0.0371
4	246.14	0.0625	0.0196	0.0335	0.0025	0.0027	0.0221	0.065	0.0169	0.0598	0.0	0.0	-0.0394
5	591.34	0.0625	0.0196	0.0298	0.0045	0.005	0.0241	0.067	0.0146	0.0575	0.0	0.0	-0.0452
6	10 646.4	0.0625	0.0196	0.0164	0.0194	0.0335	0.038	0.0809	-0.0139	0.029	0.0	0.0	-0.0904
7	4 014.25	0.0625	0.0196	0.0149	0.0037	0.0041	0.0233	0.0662	0.0155	0.0584	0.0	0.0	-0.0896
8	85 171.3	0.0625	0.0196	0.0082	0.0194	0.0335	0.038	0.0809	-0.0139	0.029	0.0	0.0	-0.1809
9	95 452.1	0.0625	0.0196	0.0066	0.0082	0.0102	0.0278	0.0707	-0.0094	0.0523	0.0	0.0	-0.2214
b	140 562.2	0.0625	0.0196	0.0055	0.0069	0.0082	0.0265	0.0694	0.0114	0.0543	0.0	0.0	-0.2520

n	[(22) × (18) - (8) × (21)] + (26)	[(23) × (10) + (11) × (21)] + (-26)	[(8) × (22) - (20) × (9)] + (26)	[(20) × (14) + (8) × (23)] + (-26)	[(25) × (10) + (14) × (21)] + (26)	[(20) × (14) + (8) × (25)] + (26)	(27) × (33) <sub>n-1</sub> + (28) × (34) <sub>n-1</sub>	(29) × (33) <sub>n-1</sub> - (30) × (34) <sub>n-1</sub>	(27) × (35) <sub>n-1</sub> + (28) × (36) <sub>n-1</sub> + (31)	(29) × (35) <sub>n-1</sub> + (30) × (36) <sub>n-1</sub> + (32)	[σ <sub>r,b</sub> - 35] <sub>b</sub> + (33) <sub>b</sub>	σ <sub>r,n</sub> (33) × (37) + (35)	σ <sub>θ,n</sub> (34) × (37) + (36)
	27	28	29	30	31	32	33	34	35	36	37	38	39
1	-	-	-	-	-	-	0.0000	1.0000	0.0000	0.0000	251 553.6	0.0	251 553.6
2	0.9424	0.0663	0.0663	0.9337	-354.2	-126.9	0.0663	0.9337	-354.2	-121.9	251 553.6	16 323.8	234 753.7
3	0.9434	0.062	0.0647	0.9326	-379.7	-126.9	0.1204	0.9751	-721.4	-273.1	251 553.6	29 565.7	219 861.5
4	0.9467	0.0584	0.0584	0.9391	-406.1	-138.1	0.1651	0.8288	-1 105.0	-436.7	251 553.6	40 426.5	208 050.9
5	0.9071	0.104	0.1062	0.8938	-876.5	-315.3	0.2360	0.7583	-1 924.3	-823.0	251 553.6	57 442.3	189 930.1
6	0.6184	0.3418	0.4812	0.5188	-9 527.6	-4 475.3	0.4051	0.5070	-10 993.9	-5 828.2	251 553.6	90 905.5	121 709.5
7	0.9230	0.0871	0.0871	0.9129	-2 965.9	-1 043.9	0.4181	0.4981	-13 625.5	-7 322.5	251 553.6	91 549.1	117 976.3
8	0.6164	0.3416	0.4809	0.5191	-38 089.3	-17 991.1	0.4279	0.4596	-48 989.4	-28 244.7	251 553.6	58 650.4	87 369.3
9	0.7981	0.1734	0.1757	0.808	-30 480.9	-11 985.4	0.4212	0.4465	-74 477.0	-43 414.6	251 553.6	31 477.4	68 904.1
b	0.8960	0.1536	0.1726	0.8409	-38 793.	-14 812.9	0.4460	0.4482	-112 192.9	-64 175.0	251 553.6	0.0	48 571.3

## REFERENCES

1. Timoshenko, S.: Strength of Materials, Part II. D. Van Nostrand Company, Inc., New York, 1956.
2. Manson, S. S.: Determination of Elastic Stresses in Gas-Turbine Disks. NACA Report 871, Cleveland, Ohio, Feb. 27, 1947.